

CURRICULUM VITAE

VEERAPANDIAN.K
pandianprabu@gmail.com
+91 9976387876

13/1 Kumarankadu,
Agasthiyampalli,
Vedaranyam-614810 ,
Nagapattinam (District),
Tamil Nadu,India.

Objective:

To establish myself as a professional with effective and efficient use of my abilities to the maximum level, thereby contributing my organization in achieving ultimate success.

Work Experience:

- (i) Organisation : Chennai Forge Products Pvt.Ltd.,Chennai,Tamilnadu.**
Designation : Quality Assurance
Period : 5th May 2011 – 15th Jun 2012

- (ii) Organisation : Pentagon Machines & services Pvt.Ltd.,Chennai,Tamilnadu.**
Designation : Production Engineer Trainee
Period : 14th July 2014 – 26th August 2016

- (iii) Organisation : Chennai Forge Products Pvt.Ltd.,Chennai,Tamilnadu.**
Designation : Draughtsman (AUTOCAD)
Period : 02nd September 2016 – 5th April 2020

- (iv) Organisation : Sir Issac Newton College of Engineering,Nagapattinam,Tamilnadu.**
Designation : Assistant Professor (**Dept: Mechanical Engineering**)
Period : 02nd January 2021 – 25th September 2023

Job Profile:

My Responsibilities of Chennai Forge Products Pvt.Ltd.(Quality Assurance):

- Customer drawing to converted in stage wise drawing.
- Knowledge in 2d &3d drawings CNC & deep draw components
- Preparation of PPAP, Control Plan, Inspection Std., and Work Instructions.
- Reducing in-house rejection through Process control.
- Ensuring product conformity by way of Layout Inspection.
- Calibration & Maintain gauge and equipment's.
- Knowledge in 2d&3d drawings.
- Implementing poka yoke to prevent recurring defects.

- Initiating corrective and preventive action by way of kaizen to in-house and customer complaints.
- Implementation 7QC tools to improve quality.
- Customer co-ordinate.
- ISO/ TS documentation.

My Responsibilities of Pentagon Machines & services Pvt.Ltd.(Production Engineer):

- Plan the schedule for production on daily basis and manage the manpower according to daily production target.
- Minimize daily rejection /rework percentage in assembly.
- Co-ordinate with QC for quality clearance of inward materials.
- Monitoring the critical shortages required by production on daily basis.
- To ensure balance flow of materials on daily basis to achieve uniform production.
- Ensure material flow in accordance with KANBAN principle & material control by using ABC principle.
- Work out the critical & expected shortages for the day to day production.
- Preparation of various types of report for the production review.
- Work out on customer complaints and take corrective actions to avoid such complaints in future.
- Daily communication with test field engineer and follow up with them to get the on time delivery of products.
- Discuss major constraints related to quality and material shortages in daily board meeting.

My Responsibilities of Chennai Forge Products Pvt.Ltd. (Draughtsman):

- Develop detailed designs for mechanical equipment and controls.
- Provide details on component descriptions.
- Develop and design the detailed specifications for components or machinery.
- Correct operating deficiencies.
- Draft technical details.
- Specify dimensions, materials, and procedures.
- Draw in minute details of structures.
- Design the parts of a machine.
- Use Computer Aided Design and Drafting systems to prepare drawings.
- Create and store drawings electronically.
- Program drawings into automated manufacturing systems.
- Prepare variations of design.
- Explain concepts to manufacturers.
- Prepare engineering drawings that detail plans and specifications.

Skill Set:

- Soft Skills Mentor
- Good Communication Skills
- Computer Literacy
- Flexible & Adaptable
- Interpersonal Abilities

Computer proficiency:

- **AutoCAD** : 2D Drafting & 3D modeling using **AutoCAD** 2013, 19.0 Version
- **CATIA V5** : Part Creation & Assembly
- **SolidWorks** : Part Creation & Assembly, Detailing using **SolidWorks 2016**
- **Packages** : Ms Office

Strength:

- Sincere
- Honest
- Dedicative
- Self Motivator
- Hard & Smart Worker
- Helping Nature

Academic Qualification:

Degree/ Examination	Year of Passing	School/Institute	Board / University	Percentage /Grade
M.E (Manufacturing Engineering)	2014	E.G.S Pillay Engineering college, Nagapattinam	Anna University Chennai	07.79 (CGPA) (First Class)
B.E (Mechanical Engineering)	2011	A.V.C College of Engineering, Mayiladuthurai.	Anna University Trichy	74.69% (First Class)
Class XII	2007	SKS Government higher Secondary School, Vedaranyam.	State Board of School Examinations, Tamilnadu	83.33%
Class X	2005	SKS Government higher Secondary School, Vedaranyam.	State Board of School Examinations, Tamilnadu	91.00%

Personal Details:

Date of Birth : 15/05/1990
Father's Name : **Mr.Kandasamy.**
Mother's Name : Mrs.Indira
Spouse Name : Mrs.Saranya
Sex : Male
Marital Status : Married
Nationality : Indian
Language known : Tamil, English
Passport Number : **X7002722**
Aadhaar Number : 5699 38000458
Permanent address : 13/1 Kumarankadu,
Agasthiyampalli,
Vedaranyam-614810
Nagapattinam (District),
Tamil Nadu,India.

Declaration:

I hereby declare that the information furnished above is true to the best of my knowledge and belief.

Yours sincerely
(VEERAPANDIAN.K)

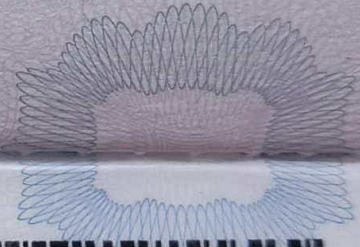
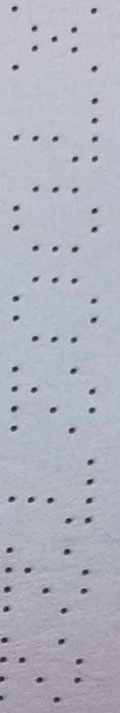

X7002722

पिता / कानूनी अभिभावक का नाम / Name of Father / Legal Guardian

KANDASAMY

माता का नाम / Name of Mother

INDIRA

पति या पत्नी का नाम / Name of Spouse

SARANYA

पता / Address

13/1, KUMARAN KADU, AGASTHIYAMPALLI PO**VEDARANYAM TK, NAGAPATTINAM****PIN: 614810, TAMIL NADU, INDIA**

पुराने पासपोर्ट का न. और इसके जारी होने की तिथि एवं स्थान / Old Passport No. with Date and Place of Issue

फाइल न. / File No.

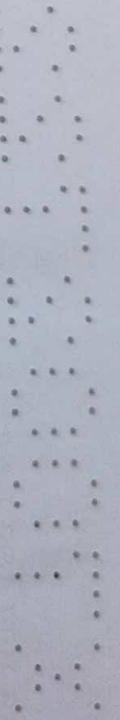
TR01C5043299523



E.G.S. PILLAY ENGINEERING COLLEGE

Approved by AICTE, New Delhi & Affiliated to Anna University, Chennai

(An ISO 9001:2008 Certified Institution)

(Co-Educational)

NAGAPATTINAM - 611 002.



T.C.No. 5704

TRANSFER & CONDUCT CERTIFICATE

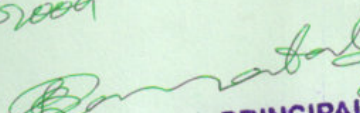
1. Name of the Student : VEERAPANDIAN. K
2. Father's Name : KANDASAMY
3. Class in which the student was studying at the time of leaving the College : M.E.,
MANUFACTURING ENGINEERING
4. Date of admission to the Course : 29/06/2012
5. Sex : MALE
6. Date of Birth as entered in the College records in figures and words : 15/05/1990
FIFTEENTH MAY NINETEEN NINETY
7. Nationality and Religion : INDIAN HINDU
8. Community as entered in the college records : BC - AGAMUDAIYAR
9. Whether completed the Course/
Qualified for promotion to higher class : YES
REFER MARK SHEET
10. Whether the student has paid all the fees to the College : YES
11. Date on which the Student left the College : 04/06/2014
12. Date of the Transfer Certificate : 11/09/2014
13. The Student's Conduct and Character : Good
14. Signature of Principal with Date and Seal : 
PRINCIPAL,
E.G.S.Pillay Engineering College
Nagapattinam.

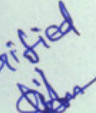

Verified

Anna University

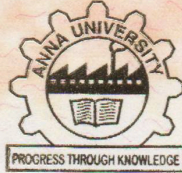

Reg.No. 820812410012/RG

The Syndicate of the Anna University hereby makes known that
VEERAPANDIAN K *has been admitted to the* **DEGREE OF MASTER OF ENGINEERING** *in* **MANUFACTURING ENGINEERING** *under the Faculty of Mechanical Engineering, having completed the prescribed programme of study and having been certified by the duly appointed examiners to be qualified to receive the same, and has been placed in **FIRST CLASS** *at the Examination held in* **JUNE 2014.***

Given under the Seal of the University

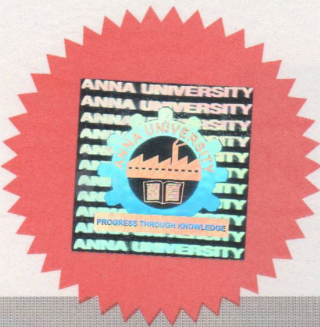

Chennai 600 025
India
November 2014
KPMCH241001063

Controller of Examinations

Registrar

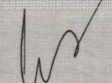
Vice-Chancellor
V110278906108

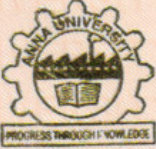

ANNA UNIVERSITY, CHENNAI - 25
M.E. DEGREE EXAMINATIONS
CONSOLIDATED STATEMENT OF GRADES



V1102778908618K

Folio No. AUC1522007

NAME OF THE CANDIDATE	VEERAPANDIAN K			REGISTER NO.	820812410012
DATE OF BIRTH	15-MAY-90	GENDER	MALE	MONTH & YEAR OF LAST APPEARANCE	JUN 2014
COLLEGE OF STUDY	E.G.S.PILLAY ENGINEERING COLLEGE			REGULATIONS	2009
PROGRAMME & SPECIALIZATION	M.E. Manufacturing Engineering				

SEM. NO.	COURSE CODE	COURSE TITLE	CREDITS	LETTER GRADE	GRADE POINT	MONTH & YEAR OF PASSING
01	MA9222	Numerical Methods and Graph Theory	4	D	6	NOV 2012
01	MF9211	Advanced Materials Technology	3	C	7	NOV 2012
01	MF9212	Automated Computer Integrated Manufacturing Systems	3	A	9	NOV 2012
01	MF9213	Advanced Manufacturing Processes	3	C	7	NOV 2012
01	MF9254	Advances in Casting and Welding Processes	3	B	8	NOV 2012
01	MF9268	Manufacturing Management	3	C	7	NOV 2012
01	MF9214	CIM Lab	2	S	10	NOV 2012
02	MF9221	Robot Design and Programming	3	C	7	JUN 2013
02	MF9222	Manufacturing Metrology and Quality Control	3	D	6	JUN 2013
02	MF9223	Metal Forming Processes	3	D	6	JUN 2013
02	MF9224	MEMS and Nanotechnology	3	D	6	JUN 2013
02	MF9261	Non-Destructive Evaluation	3	C	7	JUN 2013
02	MF9263	Lean Manufacturing system and Implementation	3	B	8	JUN 2013
02	MF9225	Automation Lab	2	A	9	JUN 2013
03	MF9251	Fluid Power Automation	3	C	7	NOV 2013
03	MF9253	Materials Management and Logistics	3	B	8	NOV 2013
03	MF9266	Financial Management	3	C	7	NOV 2013
03	MF9231	Project Work (Phase I)	6	S	10	NOV 2013
04	MF9241	Project Work (Phase II)	12	A	9	JUN 2014
*** End of Statement *** Cumulative Grade Point Average : 7.79 Classification : FIRST CLASS						



Medium of Instruction : ENGLISH

Chennai - 25.

Date : 10/07/2014

SIGNATURE OF THE STUDENT



(Signature)
 CONTROLLER OF EXAMINATIONS

Reg No.: 80107144055



The Syndicate of the Anna University Tiruchirappalli hereby makes known that VEERAPANDIAN K has been admitted to the DEGREE OF BACHELOR OF ENGINEERING in MECHANICAL ENGINEERING under the Faculty of Mechanical Engineering having completed the prescribed programme of study and having been certified by the duly appointed examiners to be qualified to receive the same and has been placed in FIRST CLASS at the Examination held in MAY 2011.



Given Under the seal of the University

ANNA UNIVERSITY TIRUCHIRAPPALLI ANNA UNIVERSITY TIRUCHIRAPPALLI ANNA UNIVERSITY TIRUCHIRAPPALLI ANNA UNIVERSITY

திருச்சிராப்பள்ளி
Tiruchirappalli-620 024
India
JUNE 2012
144SME07125548

தேர்வு நெறியாளர் (பொ)
CONTROLLER OF EXAMINATIONS (I/c)

பதிவாளர்
REGISTRAR

துணைவேந்தர்
VICE CHANCELLOR



அண்ணா பல்கலைக்கழகம் திருச்சிராப்பள்ளி
ANNA UNIVERSITY TIRUCHIRAPPALLI

Tiruchirappalli - 620 024

UG CONSOLIDATED STATEMENT OF MARKS

SERIAL NO. : 21897

FOLIO NO. : CON07M1121848

NAME OF THE CANDIDATE		VEERAPANDIAN K	
COLLEGE OF STUDY		801-A.V.C. COLLEGE OF ENGINEERING	
PROGRAMME & BRANCH		144 - B.E. MECHANICAL ENGINEERING	
DEGREE		BACHELOR OF ENGINEERING	
SEM No.	SUBJECT CODE	SUBJECT TITLE	SUBJECT TITLE
01	CS1101	Digital Computer Fundamentals	Design of Machine Elements
01	GE1101	Engineering Practice	Gas Dynamics and Jet Propulsion
01	HS1101	Technical English I	Engineering Metrology and Measurements
01	HS1102	Engineering Physics I	Dynamics Laboratory
01	HS1103	Engineering Chemistry I	Metrology and Measurements Laboratory
01	HS1104	Physics and Chemistry Laboratory I	Applied Hydraulics and Pneumatics
01	MA1101	Mathematics I	Automobile Engineering
01	ME1101	Engineering Graphics	Renewable Sources of Energy
02	CE1151	Engineering Mechanics	Heat and Mass Transfer
02	CE1151	Computer Laboratory	Design of Transmission Systems
02	GE1151	Basic Engineering	Power Plant Engineering
02	HS1151	Technical English II	Thermal Engineering Laboratory II
02	HS1152	Engineering Physics II	CAD / CAM Laboratory
02	HS1153	Engineering Chemistry II	Design and Fabrication Project
02	HS1154	Physics and Chemistry Laboratory II	Principles of Management
02	MA1151	Mathematics II	Communication and Soft Skills Laboratory
02	ME1151	Engineering Drawing Laboratory	Design of Jigs, Fixtures and Press Tools
03	CE1207	Fluid Mechanics and Machinery	Nuclear Engineering
03	CE1208	Fluid Mechanics and Machinery Laboratory	Finite Element Analysis
03	EE1211	Electrical Drives and Controls	Computer Integrated Manufacturing
03	MA1201	Mathematics III	Computer Aided Simulation and Analysis Laboratory
03	ME1201	Manufacturing Technology I	Total Quality Management
03	ME1202	Engineering Thermodynamics	Mechatronics
03	ME1203	Engineering Materials and Metallurgy	Mechatronics Laboratory
03	ME1204	Manufacturing Technology Laboratory	Maintenance Engineering
04	CE1258	Strength of Materials	Project Work
04	CE1259	Strength of Materials Laboratory	Engineering Economics and Cost Analysis
04	EC1260	Electronics and Microprocessors	Production Planning and Control
04	EC1261	Electronics and Microprocessors Laboratory	*** End of Statement ***
04	MA1251	Numerical Methods	
04	ME1251	Thermal Engineering	
04	ME1252	Kinematics of Machinery	
04	ME1253	Manufacturing Technology II	
04	ME1254	Thermal Engineering Laboratory	
05	HS1201	Environmental Science and Engineering	
05	ME1258	Computer Aided Machine Drawing Practice	
05	ME1301	Dynamics of Machinery	

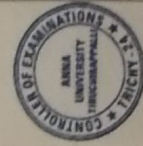

Tiruchirappalli - 620 024

Date : 20/09/2011

TOTAL MARKS : 3660/4900

PERCENTAGE : 74.69

TOTAL MARKS (from 3rd to 8th semester)

IM - Internal Assessment Marks

UM - University Examination Marks

TOT - Total

Controller of Examinations

அரசுத் தேர்வுகள் துறை, சென்னை - 600 006.
DEPARTMENT OF GOVERNMENT EXAMINATIONS, CHENNAI - 600 006.

மேனிலைப் பள்ளிக் கல்விச் சான்றிதழ்
HIGHER SECONDARY COURSE CERTIFICATE

பொதுக்கல்வி / GENERAL EDUCATION
தமிழ்நாடு அரசின் அதிகாரத்திற்கு உட்பட்டு வழங்கப்படுகிறது
ISSUED UNDER THE AUTHORITY OF THE GOVERNMENT OF TAMILNADU

தேர்வர் VEERAPANDIAN. K

MAR. 2007 இல்

மேனிலைப் பள்ளி இறுதி வகுப்புப் பொதுத் தேர்வெழுதி கீழ்க்காணும் மதிப்பெண்களைப் பெற்றுள்ளார் என்று சான்றளிக்கப்படுகிறது.

Certified that the above mentioned candidate appeared for the Higher Secondary Public Examination and obtained the following marks :

பாடம் SUBJECT	கருத்தியல் THEORY 150	செய்முறை PRAC. 50	பெற்ற மதிப்பெண் 200 க்கு MARKS OBTAINED FOR 200	
TAMIL			174	ONE SEVEN FOUR
ENGLISH			144	ONE FOUR FOUR
PHYSICS	117	050	167	ONE SIX SEVEN
CHEMISTRY	133	050	183	ONE EIGHT THREE
BIOLOGY	134	050	184	ONE EIGHT FOUR
MATHEMATICS			148	ONE FOUR EIGHT

மொத்த மதிப்பெண்

TOTAL MARKS 1000 ONE ZERO ZERO ZERO

பிறந்த நாள் / DATE OF BIRTH

15/05/90

பதிவெண் / REGISTER NO.

431680

ம.அ.ப. குறியீட்டெண் & நாள் / TMR CODE NO. & DATE

G278339 14. 05. 2007

பள்ளியின் பெயர் / NAME OF THE SCHOOL

S. K. S. GOVT HSS VEDARANIAM

பாடத் தொகுப்பு எண் / GROUP CODE

103

தேர்ச்சிக்கான குறும் அளவு : ஒவ்வொரு பாடத்திலும், 200க்கு 70 மதிப்பெண் பெறவேண்டும். இது பகுதி முறையில் தேர்வெழுதித் தேர்ச்சி பெறுவதற்கும் பொருந்தும். கருத்தியல் மற்றும் செய்முறைத் தேர்வுகள் கொண்ட பாடங்களில் தேர்ச்சி பெற கருத்தியல் தேர்வில் 150க்குக் குறும் அளவு 30 மதிப்பெண்களும், செய்முறைத் தேர்வில் 50க்குக் குறும் அளவு 40 மதிப்பெண்களும் பெறவேண்டும்.

Minimum for a Pass: 70 Marks out of 200 in each subject. This includes passing under the compartmental system also. For the subjects consisting of Theory and Practical Examinations Minimum Marks for a Pass is 30 out of 150 in Theory and 40 out of 50 in Practical.

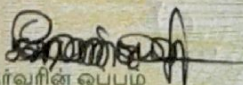
தேர்வரின் ஒப்பம்

Candidate's Signature

செயலாளர்

மாநிலப் பள்ளித் தேர்வுகள் குழுமம், தமிழ்நாடு
SECRETARY
STATE BOARD OF SCHOOL EXAMINATIONS, TAMILNADU

அரசுத் தேர்வுகள் துறை, சென்னை - 600 006.

DEPARTMENT OF GOVERNMENT EXAMINATIONS, CHENNAI - 600 006.

இடைநிலைக் கல்வி பள்ளி இறுதி வகுப்புச் சான்றிதழ்
SECONDARY SCHOOL LEAVING CERTIFICATE

பத்தாம் வகுப்பு

X STANDARD

தமிழ்நாடு அரசின் அதிகாரத்திற்கு உட்பட்டு வழங்கப்படுகிறது
ISSUED UNDER THE AUTHORITY OF THE GOVERNMENT OF TAMILNADU

தேர்வர் VEERAPANDIAN, K

MAR. 2005 இல்

பத்தாம் வகுப்புப் பொதுத் தேர்வெழுதிக் கீழ்க்காணும் விழுக்காட்டு மதிப்பெண்களைப் பெற்றுள்ளார் என்று சான்றளிக்கப்படுகிறது.

Certified that the above mentioned candidate appeared for the SSLC Public Examination and obtained the following percentage of marks :

பாடம் SUBJECT	மதிப்பெண் MARKS
மொழி LANGUAGE	90 NINE ZERO
ஆங்கிலம் ENGLISH	88 EIGHT EIGHT
கணிதம் MATHEMATICS	92 NINE TWO
அறிவியல் SCIENCE	95 NINE FIVE
சமூக அறிவியல் SOCIAL SCIENCE	90 NINE ZERO
மொத்தம் TOTAL	455 FOUR FIVE FIVE

பிறந்த நாள் / DATE OF BIRTH 15.05.1990	பதிவெண் / REGISTER NO. 433172	ம.அ.ப.குறியீட்டுக் குறியீட்டு எண் & நாள் / TMR CODE NO. & DATE A406949 04.06.2005
பள்ளியின் பெயர் / SCHOOL S K S GOVT HSS VEDARANIYAM		

பத்தாம் வகுப்புத் தேர்வில் தேர்ச்சி பெற ஒவ்வொரு பாடத்திலும், 100க்குக் குறாம அளவு முப்பத்தைந்து விழுக்காடு மதிப்பெண் பெறுதல் வேண்டும். இது பகுதி முறையில் தேர்வு எழுதித் தேர்ச்சி பெறுவதற்கும் பொருந்தும்.

A PASS IN THE SSLC (X STD.) EXAMINATION REQUIRES A MINIMUM OF THIRTY FIVE PERCENT OF MARKS IN EACH ONE OF THE FIVE SUBJECT. THIS INCLUDES PASSING UNDER THE COMPARTMENTAL SYSTEM ALSO.

க. வீரபாண்டியன்

தேர்வரின் ஒப்பம்
Candidate's Signature

SSLC

செயலாளர்

மாநிலப் பள்ளித் தேர்வுகள் குழுமம், தமிழ்நாடு
SECRETARY
STATE BOARD OF SCHOOL EXAMINATIONS, TAMILNADU



Chennai Forge Products Pvt. Ltd.

Manufacturers of Quality Steel Forgings



REGD. OFFICE & FACTORY :

PLOT No. OLD 67, NEW 57,
SIDCO INDUSTRIAL ESTATE,
AMBATTUR, CHENNAI - 600 098.

E-mail : chenbest@vsnl.net / chennaiforge@gmail.com

Website : www.chennaiforgeproducts.com



Phone : 26252859 / 26246752

Fax : 044-2635 7045

TIN No. : 33291441740

CST No. : 767343 / Dt. 27.03.2001

SME RATING : C5; D&B-D-U-N-S : 86-249-5541

19.06.12

TO WHOMSOEVER IT MAY CONCERN

This is to certify that Mr.K.VEERAPANDIAN worked in CHENNAI FORGE PRODUCTS PVT LTD, from May - 2011 to June2012. At the time of leaving he was designated as ENGINEER-QA at our Organisation.

Throughout the career here, he did his work sincerely. He has left us with the good record. We wish him very best in his future assignments.

Yours Faithfully,

For CHENNAI FORGE PRODUCTS PVT LTD

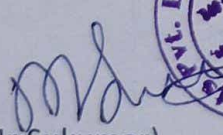
(Mr.Sukumar)

Manager - HR



PENTAGON

MACHINES AND SERVICES PRIVATE LIMITED

Sidco Plot 12, Sidco Ambattur Industrial Estate, Chennai-600 098, India

Tel: 2625 1920, 2625 6152, Fax: +91-44-2625 3063

E mail: pentagon@sellvindsgroup.com

Aug 30, 2016

SERVICE CERTIFICATE

Name	:	Mr. K.Veerapandian
Designation	:	Production Engineer Trainee
Date of Joining	:	14.06.2014
Date of Leaving	:	26.08.2016
Reasons for Leaving	:	Resignation
Performance	:	Satisfactory
Conduct	:	Satisfactory

For PENTAGON MACHINES AND SERVICES PRIVATE LIMITED,

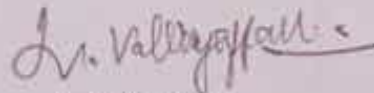

L. Valliyappan
General Manager



Regd. Office:
"Sri Bhuvaneswar"
3362 AX, XI Main Road
Annanagar West
Chennai 600 040, India



Chennai Forge Products Pvt. Ltd.

Plant I : Forging Unit



Plot No, New No: 57, Old No: 67,
SIDCO Industrial Estate (North),
Sector 1, 3rd Street, Ambattur,
Chennai -600 098, Tamil Nadu.

E-mail : info@chennaiforgeproducts.com
Website : www.chennaiforgeproducts.com



Phone : +91-44-2625 2859 / 4320 4800

Fax : +91-44-2635 7045

GSTIN : 33AABCC4668E1ZW/Dt. 01.07.2017

CIN : U28910TN2000PTC044212

20-04-2020

TO WHOMSOEVER IT MAY CONCERN

This is to certify that **Mr.VEERAPANDIAN.K** has worked in our organization in the position of **DRAUGHTSMAN (AUTOCAD)** from **02nd September 2016** to **05th April 2020**.

His major responsibilities included planning & creating mechanical designs using AutoCAD, developing product drawings.

Throughout the career here, he did his work sincerely and his performance was very good. He has left us with the good record. We wish him all the very best in his future career endeavours.

For CHENNAI FORGE PRODUCTS PVT LTD.

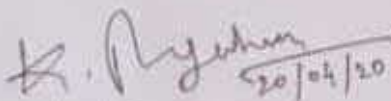

20/04/20

(K.RAGHAVAN)

MANAGER-HR

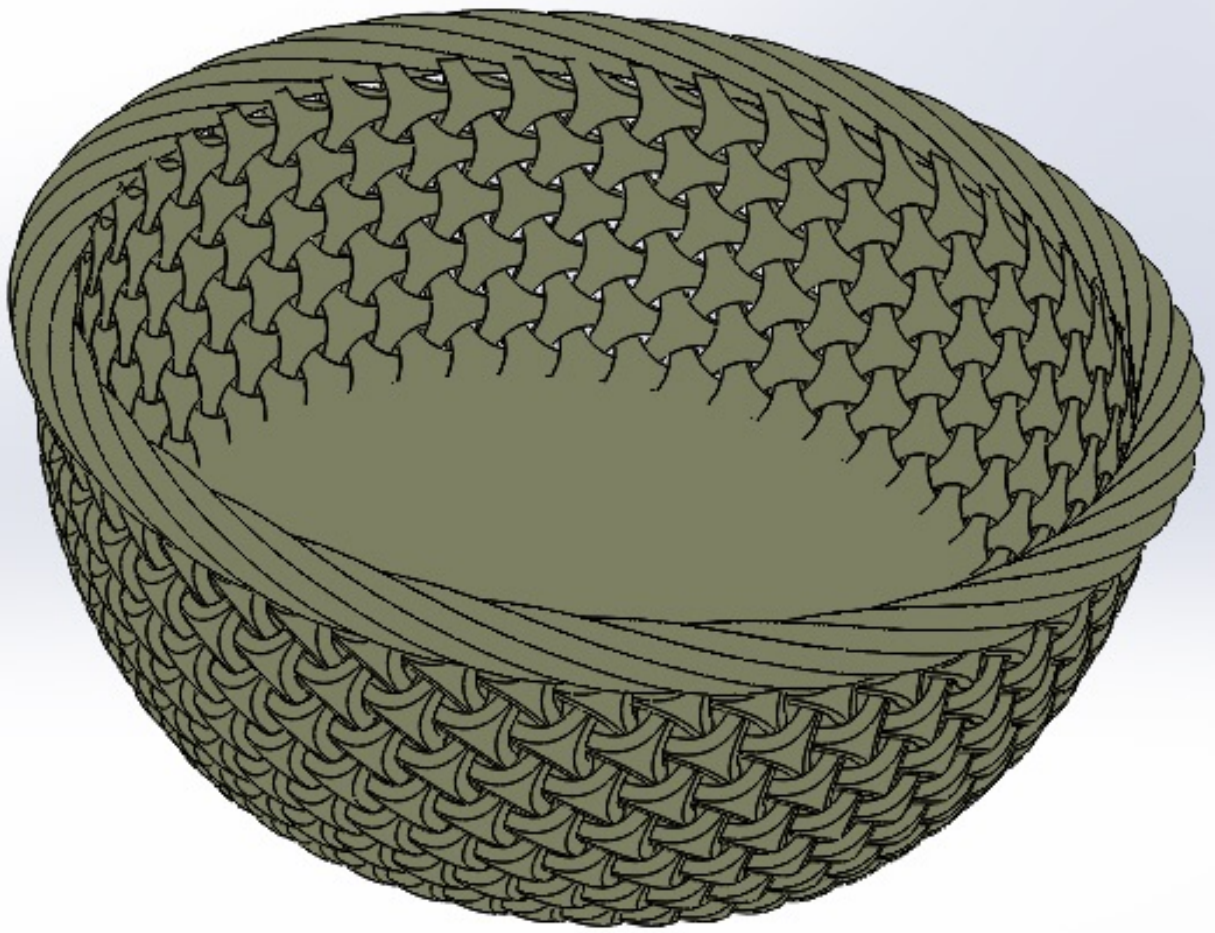

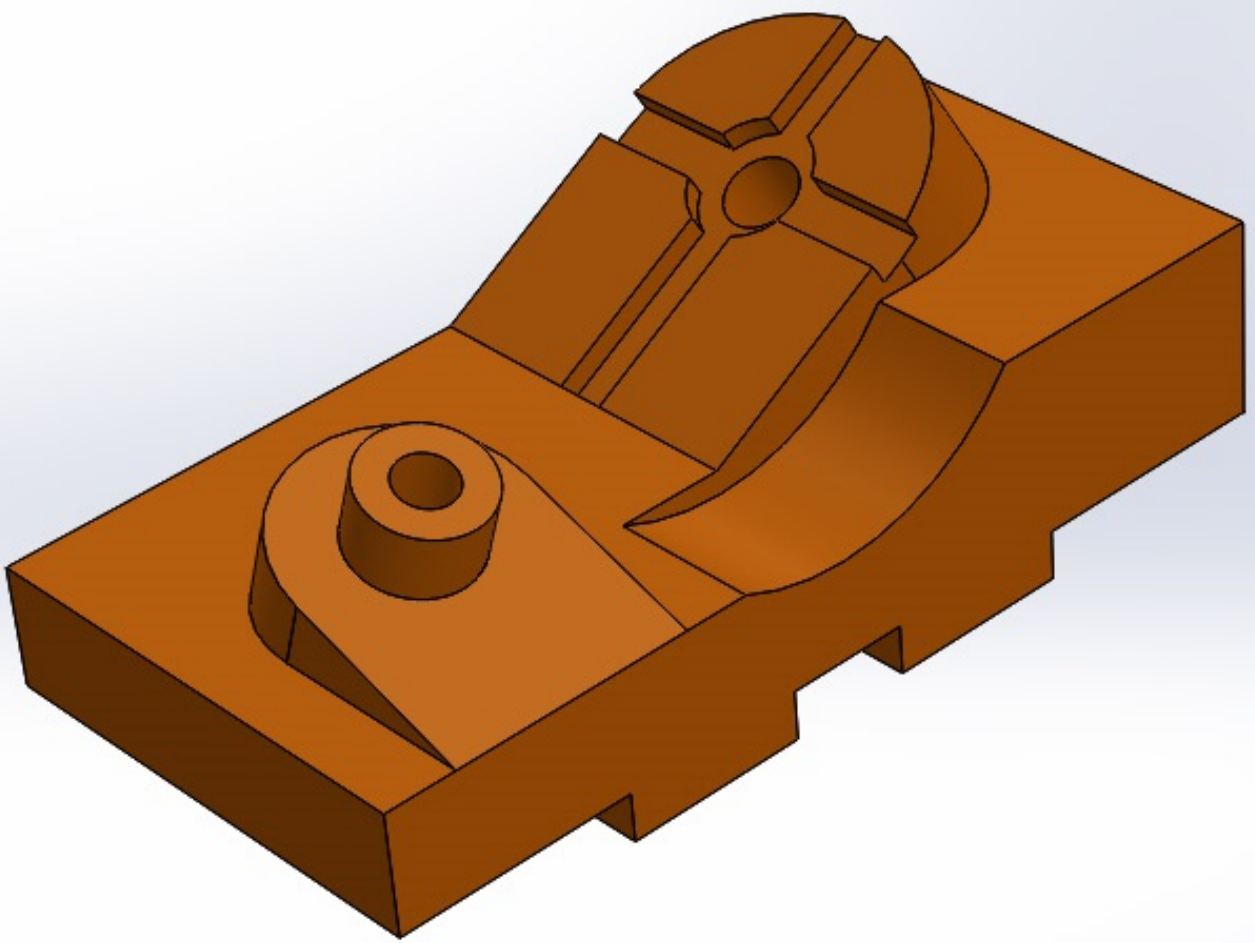



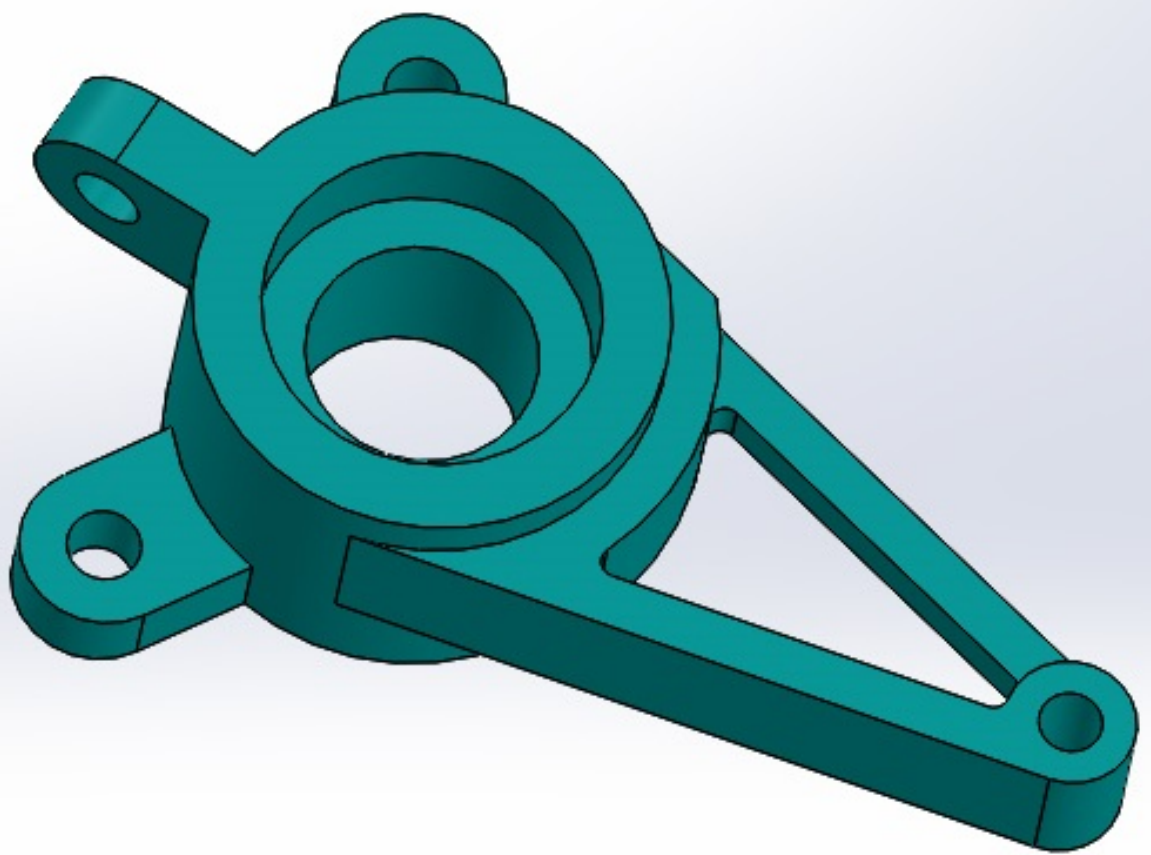

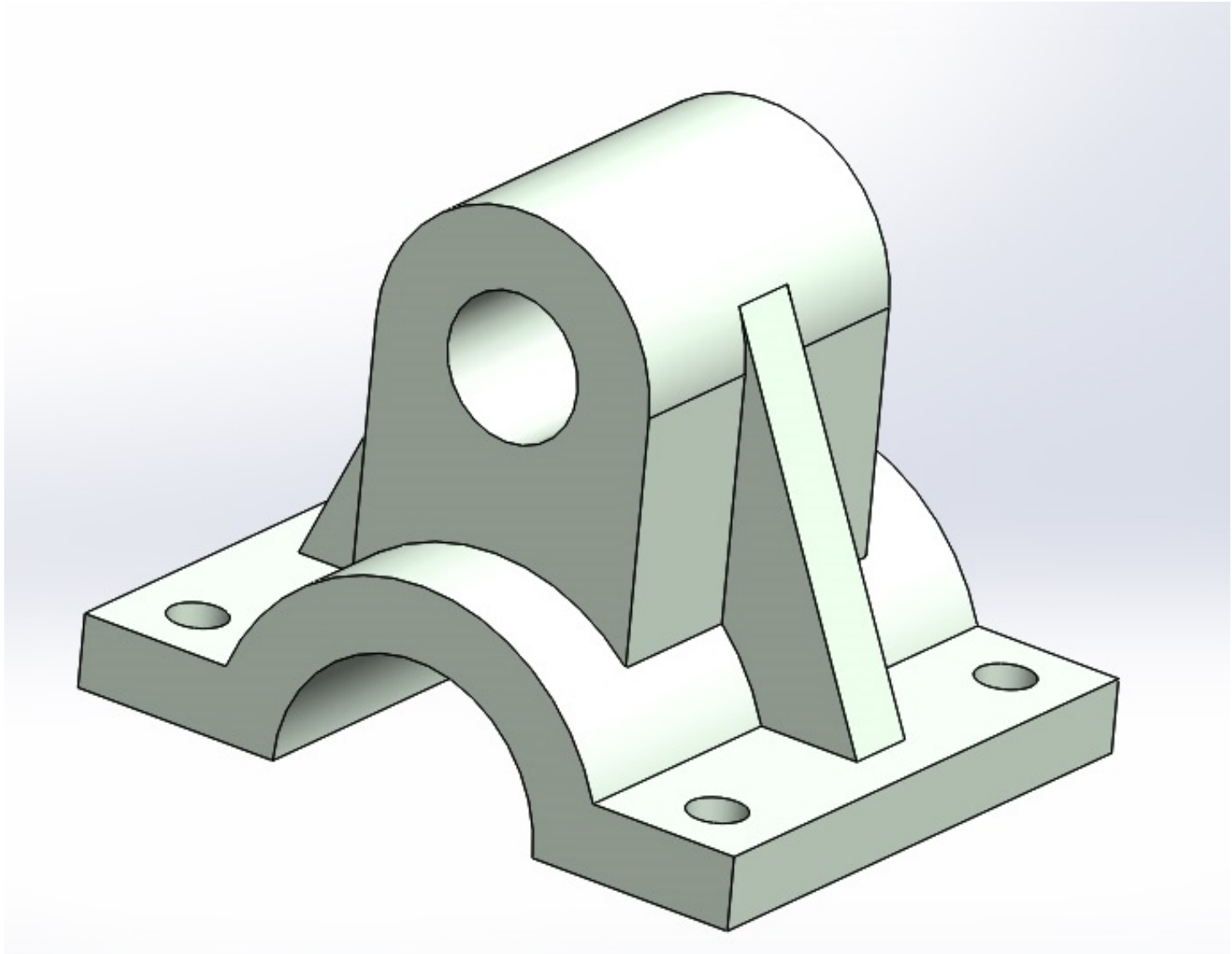

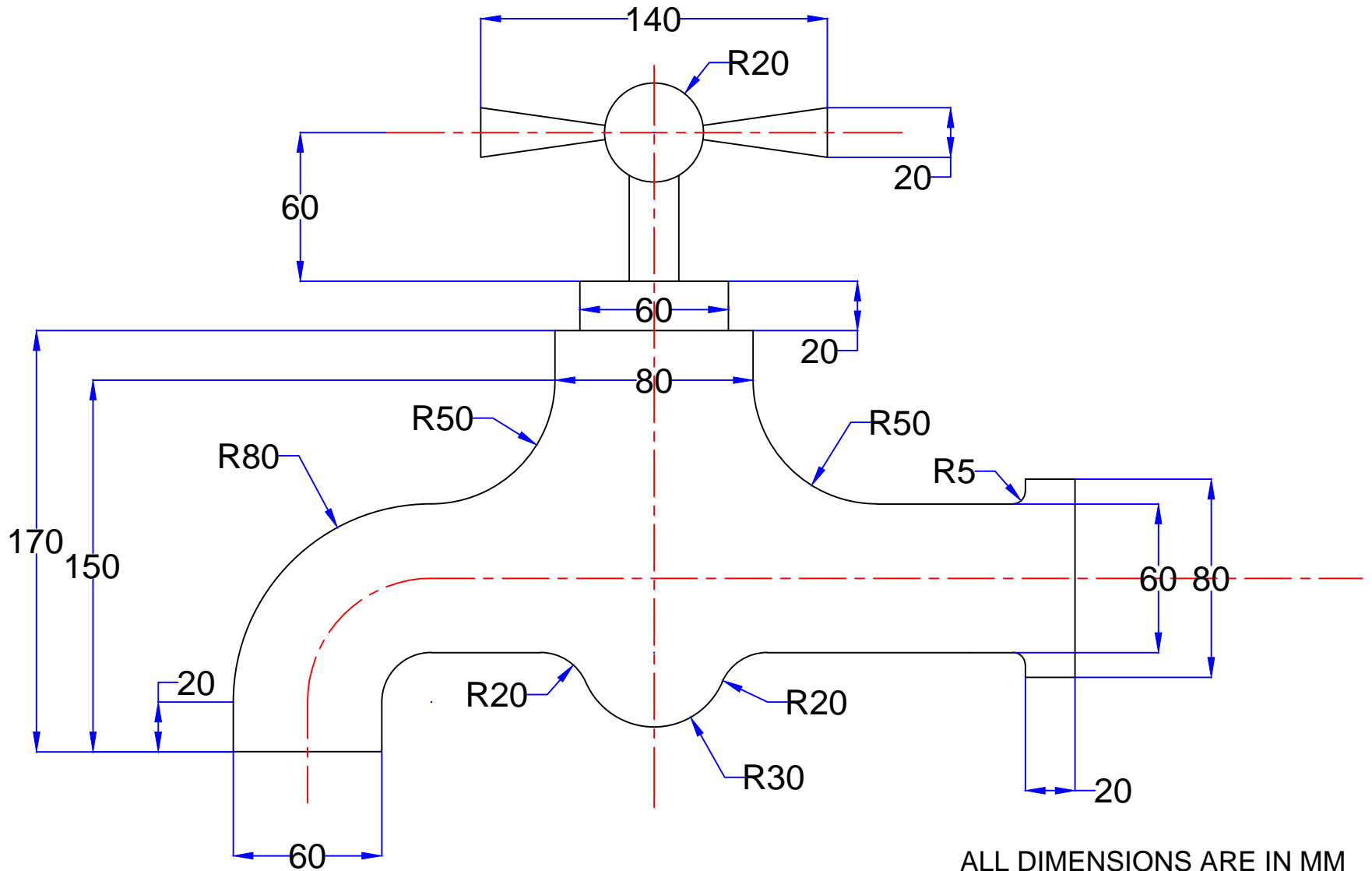

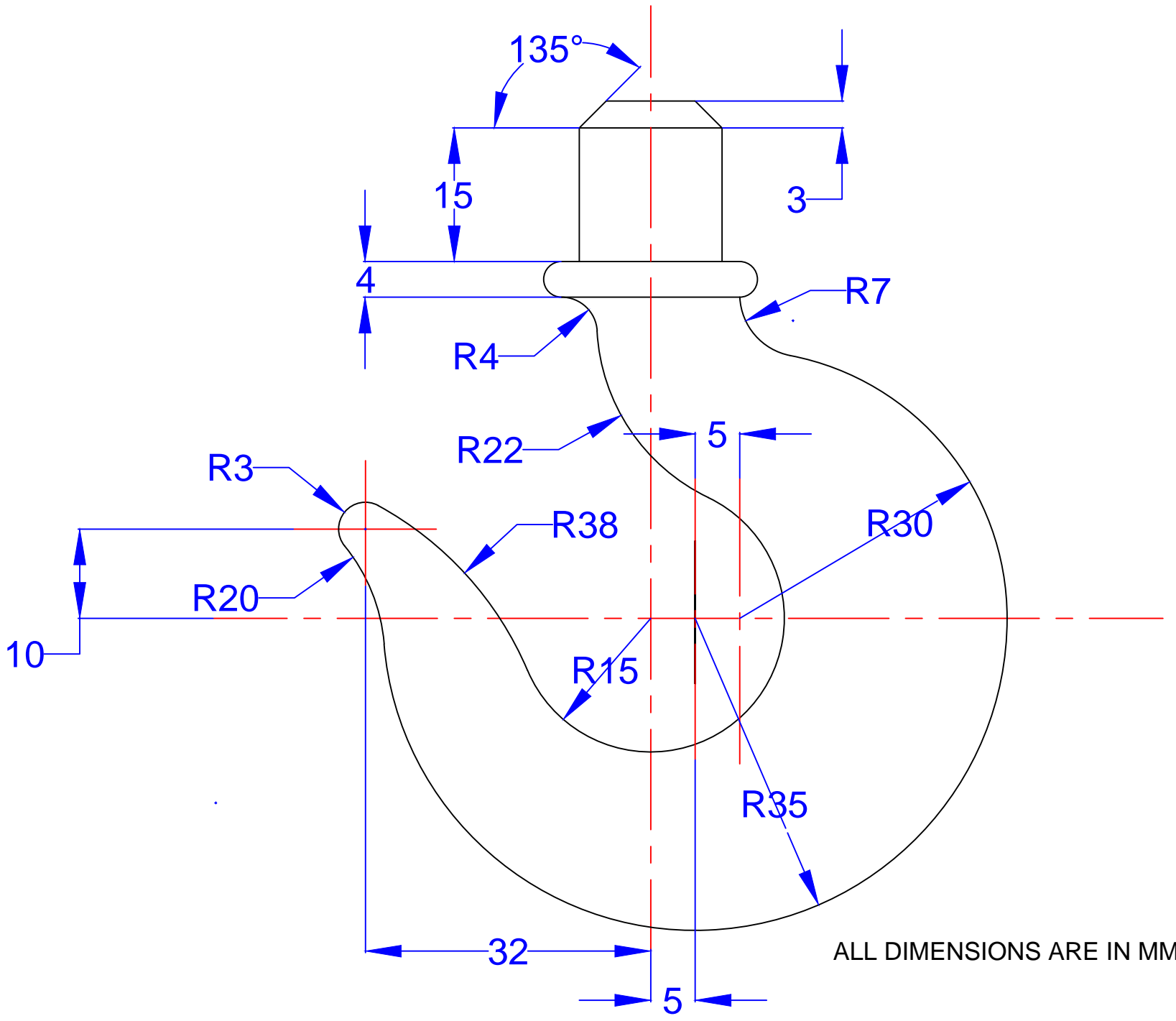

ALL DIMENSIONS ARE IN MM

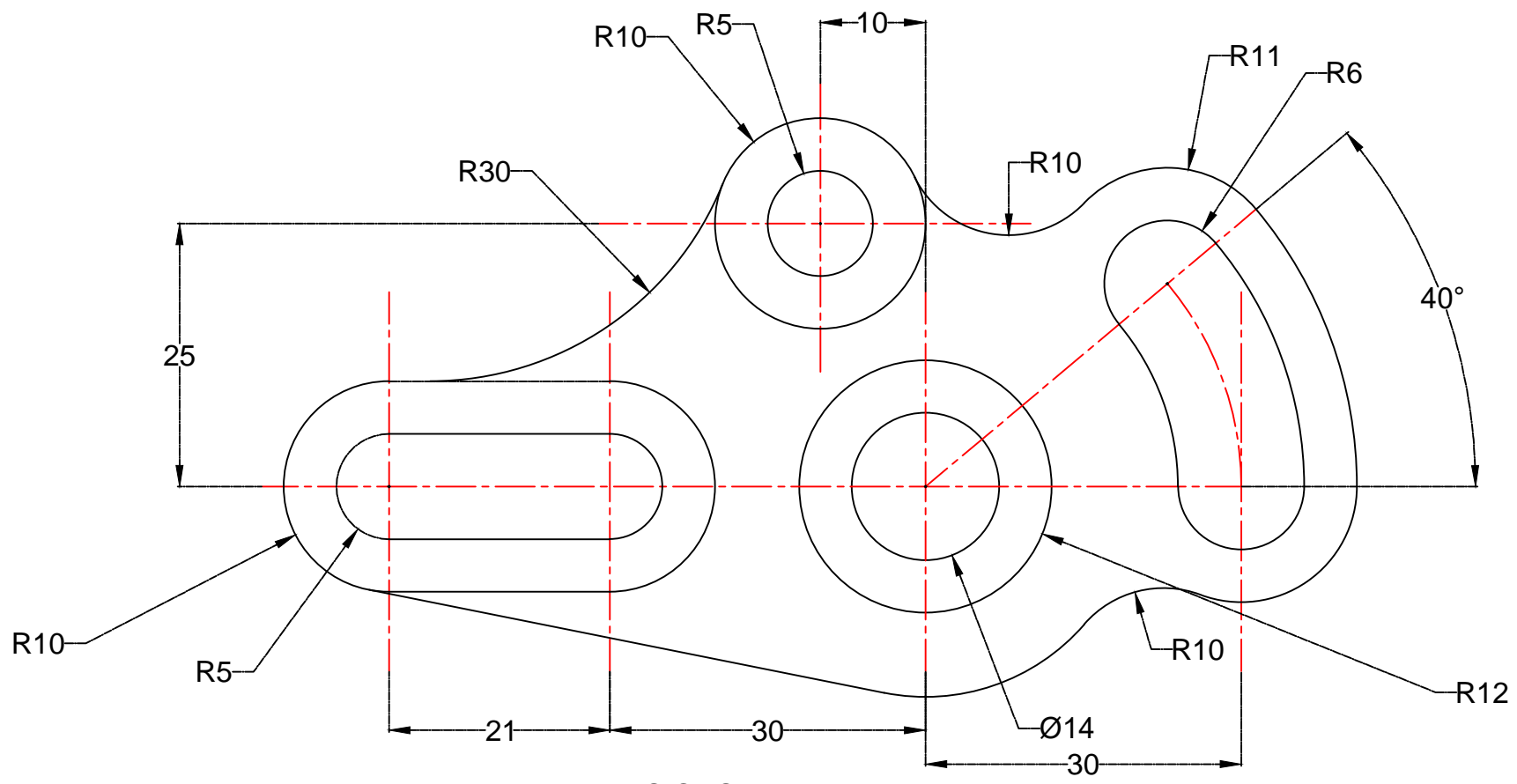

ALL DIMENSIONS ARE IN MM